

IMfinity® CILS IE4 Cast Iron

Three-phase induction motors

225 to 315 frame sizes
37 to 200 kW – 2 & 4 poles

LEROY-SOMER™

Nidec
All for dreams

A complete range from a renowned drive system expert



Benchmark technologies

Cutting-edge technologies and technical expertise have made Nidec Leroy-Somer a reference in industrial & commercial drive systems. Whatever you are looking for, induction or synchronous motor range, geared motors, brake motors, variable speed drives, soft starters..., there is a Nidec Leroy-Somer solution for you.

For many years, the energy efficiency of its motors has been at the heart of Nidec Leroy-Somer research & development, enabling it to offer the most extensive range rating from IE2 to IE5 efficiency levels for various applications among which:



IMfinity®

The most complete induction motor range

IMfinity® a quality reference in induction motors

Among its iconic ranges, the proven multi-purpose IMfinity® induction motors provide extended features for a simple integration worldwide, in standard & safety environments:

- High reliability
 - Fixed or variable speed
 - Energy efficiency up to IE4
 - Multi-voltage / multi-frequency for global compatibility
 - Compliant to most international standards
 - Easy commissioning & maintenance
 - Multiple combinations (brake, gearbox, integrated drive)
 - Many options available & Customization possible for specific projects
 - Aluminium, steel or cast iron
- 0.09 to 1,500 kW / Up to 4,500 rpm / IP23 & IP55 / 56 to 500 mm / 2,4,6 poles



Quick 360° view of the IMfinity®



Nota: Features vary according to models.

CILS

The latest addition to the IMfinity® line

IMfinity® CILS the new cast iron IE4 series

Developed to reduce drastically the energy consumption of the machines while maintaining maximum level of robustness and performance, the new Super Premium IE4 cast iron CILS series is integrating the global IMfinity® range. The IMfinity® CILS is compliant to the ecodesign requirement of the EU 2009/125/EC directive and to the Commission Regulation UE 2019/1781 on induction electric motors. Indeed, starting July 2023, electric motors with a power between 37 kW and 200 kW and covered by the regulation must have an energy efficiency level of IE4 minimum.

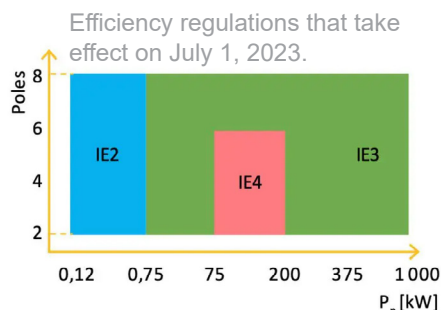
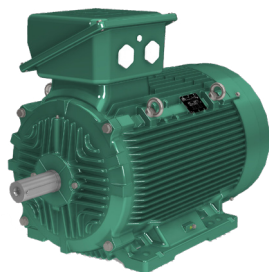

The CILS cast iron 3-phase induction motor is a general-purpose range designed for industrial applications to offer robustness, IE4 energy efficiency and flexibility of mounting.

Based on the well-known IMfinity® motor platform, the CILS series is mainly oriented on Fan, Pump and Compressor applications, while benefiting from the great expertise of Nidec Leroy-Somer in manufacturing reliable, powerful and adaptable motors.

Developed from the electrical core of the IMfinity® range, the CILS series benefits from a new up-to-date cast iron mechanical design, optimized and adapted for standard application requirements:

Main features:

- IEC Standard
- 2, 4 poles
- IP55
- Frame sizes: 225-315
- IM1001 (B3), IM 2001 (B35), IM 3011 (V1)
- Standard Operating voltage: 380/400/415V / 50Hz & 460V / 60Hz
- IE4 Efficiency Level
- Ambient temperature: -20°C ; +50°C
- Vibration levels (half-key balancing) of Grade A (IEC 60034-14)
- Winding thermal protection: PTC
- Multi-position terminal box
- Pre-drilled terminal box
- Earthing bolt on feet and terminal box
- Stainless steel nameplate
- Paint system: C3L / ISO 12944-2
- Certificates: CE, CURUS, UKCA

Internal Options:

- Winding thermal sensor (PT100, PTO)
- Space heater (230V)
- End-shield thermal protection (PTC, PT100, PTO)
- Special Bearing (roller bearing)
- NDE Isolated bearing
- Shaft Grounding ring

External Options:

- Left or right terminal box with mechanical adapter
- Nameplate adaptation
- Drip cover
- Plastic or metallic cable glands
- Specific color

IMfinity® CILS IE4 Super Premium energy efficiency

Reduce energy bill & carbon footprint

The IMfinity® CILS electric motors ensure energy consumption reduction thanks to its IE4 Super Premium efficiency level (defined in IEC 60034-30-1:2014), contributing to sustainability, lower carbon footprint and energy bill savings. It also offers an excellent cost-benefit ratio, as the total cost of ownership of an induction motor is mainly due to its electric consumption over its lifetime (see Figure 1).

With the IMfinity® CILS, it's also easy to upgrade the efficiency of an existing application/equipment as it's an IEC mechanics designed motor with an extended versatility of installation.

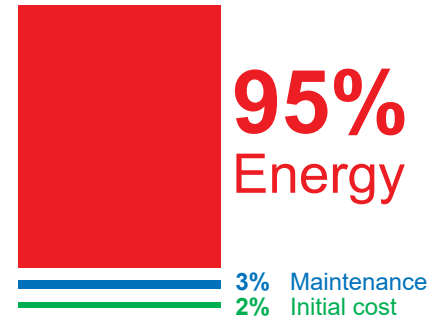
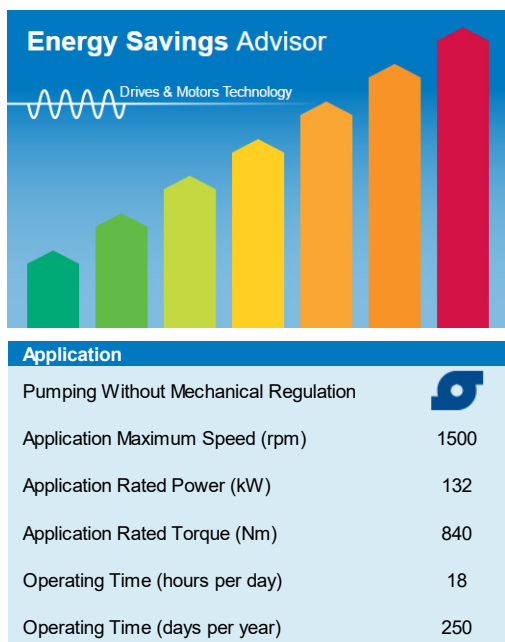

Fig. 1: Global cost of an electric motor over 10 years

IE4 vs IE3 savings comparison using ESA simulation tool

If you compare an IE4 IMfinity® CILS motor to a generic IE3 equivalent model, you will clearly see the savings you can achieve (see the example in Figure 2).



The IE4 4P CILS 315 frame size, 132 kW, offers an efficiency rate of 96.4% versus 95.6% for an IE3 equivalent model, generating more than 5100 kWh saved per year.

| Motor | | Existing - IE3 | IMfinity - IE4 |
|---------------------------|------------------|----------------------------|-------------------------|
| | Type | 4P Generic IE3 315M 132 kW | 4P CILS IE4 315M 132 kW |
| | Efficiency Class | IE3 | IE4 |
| | Power (kW) | 132 | 132 |
| | Efficiency (%) | 95,6 | 96,4 |
| Energy Consumption | | Existing - IE3 | IMfinity - IE4 |
| (kWh/Year) | | 621 320 | 616 152 |
| Savings (kWh/year) | | 5 168 | |

Fig. 2: Comparison of IE4 vs IE3 IMfinity® induction motor with the ESA application from Nidec Leroy-Somer

IMfinity[®] CILS

The flexibility of an adaptative design

The IMfinity[®] CILS motor range has been ergonomically designed to make its adoption as simple and convenient as possible for the users whether they are OEM machine builders or end-users.

It includes as standard many arrangements to facilitate its adaptation and integration while limiting the number of references and spares in stock and improving lead times and availability.

Smart design of the terminal box for a greater flexibility of installation

Versatile multi-position terminal box

Placed as standard on the top of the motor, the terminal box can also be located on the left or right side as an option, as the same box is used. Thus, the airflow is improved, there are no more losses due to terminal box indentations on the left and right of the housing and the concentration of the volumes is optimized. The late adaptation in factory or at customer's facility is even easier, allowing reduced lead times.

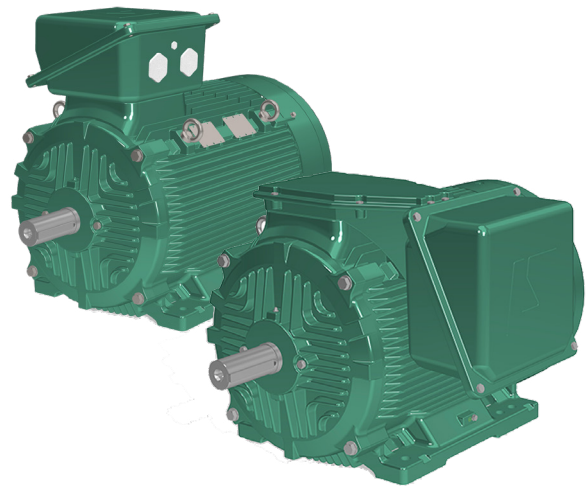

Pre-drilled terminal box

For an effortless installation, the terminal box is pre-drilled in factory including plastic plugs as standard but can be optionally equipped with plastic or metal cable glands.

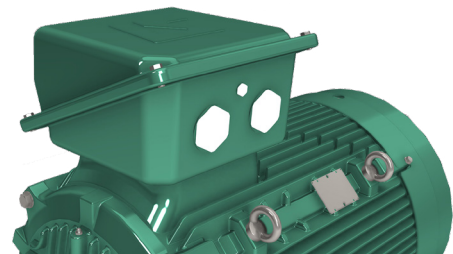

Earth terminal inside the terminal box

Grounding is easy thanks to special locations inside the terminal box and on the housing feet.



IMfinity[®] CILS

Less stock, more capabilities

In addition to the versatile new terminal box, many other elements have been developed to reduce the number of references and related level of stock to manage while maximizing late customization capabilities and decreasing lead times.

Effortless and time saving!

Only one stator diameter per frame size

To simplify and mutualize the management of mechanical options (flanges ...).

B3 convertible in B35

The feet-mounted CILS motors are easily converted to B35 configuration (with flange).

Prepared for drip cover

The rear cover is pre-equipped for a drip cover integration in case of operation in vertical position, shaft end facing down.

Shaft with captive keyway

To facilitate assembly in vertical shaft mounting.

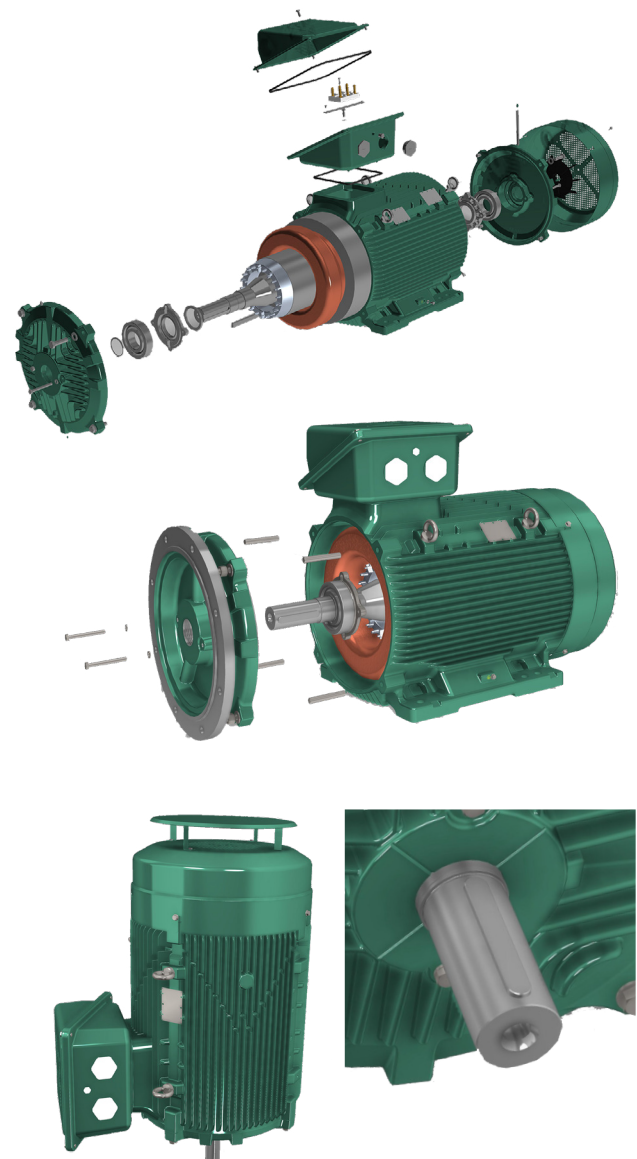

IMfinity[®] CILS

The robustness of an advanced reliable design

The IMfinity[®] CILS has been designed to further improve reliability and lifetime of the motor while facilitating its maintenance and serviceability.

Reinforced Protective design

Internal grounding ring

The drive end shield is designed to receive an AEGIS ring (current between housing & shaft) thanks to specially adapted machining of the inner cover, enabling protected internal mounting. Late customisation is possible in factory or at customer facility reducing lead times (Mounting option on stock machine).

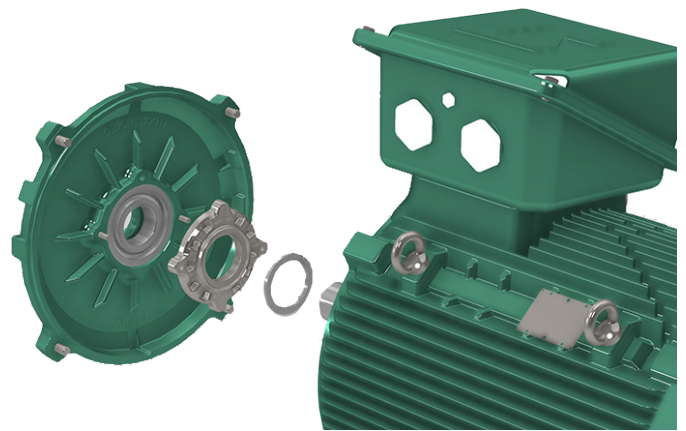

Rubber-free Sealing

Sealing at the front and rear without rubber seal, using decompression grooves to limit motor wear parts, simplify maintenance and reduce losses.

Mechanically adapted to applications

The drive-end bearing is fixed mounted whereas the non drive-end bearing is mounting-free. This is particularly useful for pumping applications.

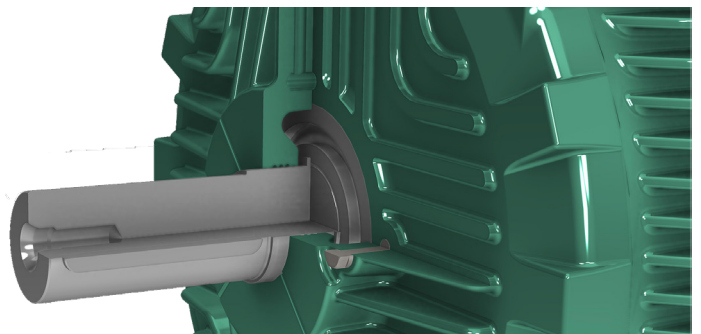

IMfinity® CILS

Main Electrical & Mechanical Characteristics

IMfinity® 3-phase induction motors
 IP55 Cast iron frame
 Electrical and mechanical characteristics
 IE4 - Powered by the mains

IMfinity® CILS electrical data - Direct On Line

| Type | IE4 EFFICIENCY LEVEL - Direct On Line | | | | | | | | 400V / 50Hz | | | | | | | |
|---------------|---------------------------------------|----------------|----------------------------------|------------------------------|------------------------------------|-----------------------|--------------|-------------|---------------|-----------------|---------------------------|------|------|---------------------------|------|------|
| | Nominal Power | Nominal Torque | Starting Torque / Nominal torque | Max. Torque / Nominal Torque | Starting Current / Nominal Current | Inertia | Mass (IM B3) | Noise level | Nominal speed | Nominal Current | Efficiency level - η | | | Power factor - Cos ϕ | | |
| | Pn - kW | Mn - N.m | Md/Mn | Mm/Mn | Id/In | J - Kg.m ² | kg | LP-db(A) | Nn - Min-1 | In - A | 4/4 | 3/4 | 2/4 | 4/4 | 3/4 | 2/4 |
| 2 pole | | | | | | | | | | | | | | | | |
| CILS 225 M | 45 | 144 | 2.65 | 4.00 | 8.75 | 0.35 | 368 | 80 | 2980 | 76.7 | 95.1 | 95.0 | 94.1 | 0.89 | 0.86 | 0.78 |
| CILS 250 M | 55 | 176 | 2.75 | 4.00 | 8.95 | 0.42 | 460 | 80 | 2978 | 92.0 | 95.9 | 95.7 | 95.0 | 0.90 | 0.87 | 0.80 |
| CILS 280 SG | 75 | 241 | 2.15 | 3.20 | 6.90 | 1 | 810 | 80 | 2978 | 125 | 95.6 | 95.3 | 94.4 | 0.90 | 0.88 | 0.81 |
| CILS 280 MG | 90 | 289 | 2.10 | 3.05 | 6.70 | 1.05 | 840 | 80 | 2978 | 153 | 95.8 | 95.6 | 94.7 | 0.89 | 0.87 | 0.79 |
| CILS 315 SE | 110 | 353 | 2.20 | 3.09 | 6.75 | 1.2 | 890 | 80 | 2978 | 188 | 96.0 | 95.8 | 95.0 | 0.88 | 0.87 | 0.82 |
| CILS 315 ME | 132 | 423 | 2.05 | 2.85 | 6.35 | 1.25 | 940 | 80 | 2976 | 223 | 96.2 | 95.8 | 95.3 | 0.88 | 0.87 | 0.82 |
| CILS 315 LE | 160 | 512 | 2.85 | 3.69 | 8.35 | 1.44 | 1050 | 80 | 2982 | 273 | 96.3 | 96.0 | 95.0 | 0.88 | 0.85 | 0.77 |
| CILS 315 LE | 200 | 642 | 2.06 | 2.65 | 6.25 | 1.62 | 1140 | 80 | 2976 | 329 | 96.5 | 96.3 | 95.8 | 0.91 | 0.90 | 0.86 |
| 4 pole | | | | | | | | | | | | | | | | |
| CILS 225 S | 37 | 237 | 2.7 | 3.15 | 8.25 | 0.38 | 388 | 70 | 1488 | 69.2 | 95.3 | 95.5 | 95.1 | 0.81 | 0.76 | 0.66 |
| CILS 225 M | 45 | 289 | 2.85 | 3.00 | 8.90 | 0.79 | 423 | 70 | 1488 | 85.1 | 95.4 | 95.4 | 94.9 | 0.80 | 0.75 | 0.64 |
| CILS 250 M | 55 | 352 | 2.84 | 4.19 | 9.50 | 1.08 | 555 | 70 | 1490 | 98.4 | 96.0 | 95.9 | 95.4 | 0.84 | 0.79 | 0.67 |
| CILS 280 SG | 75 | 481 | 2.81 | 3.41 | 8.80 | 1.82 | 860 | 70 | 1490 | 132 | 96.1 | 96.0 | 95.3 | 0.86 | 0.83 | 0.74 |
| CILS 280 MG | 90 | 577 | 3.05 | 3.66 | 9.45 | 2.06 | 912 | 70 | 1490 | 156 | 96.2 | 96.1 | 95.4 | 0.87 | 0.85 | 0.74 |
| CILS 315 SE | 110 | 706 | 3.11 | 3.60 | 9.05 | 2.31 | 980 | 75 | 1490 | 194 | 96.3 | 96.1 | 95.4 | 0.85 | 0.83 | 0.76 |
| CILS 315 ME | 132 | 847 | 3.20 | 3.55 | 9.20 | 2.68 | 1090 | 75 | 1490 | 233 | 96.4 | 96.1 | 95.4 | 0.85 | 0.83 | 0.76 |
| CILS 315 LE | 160 | 1026 | 2.90 | 3.20 | 8.40 | 2.92 | 1155 | 75 | 1488 | 275 | 96.6 | 96.5 | 95.9 | 0.87 | 0.83 | 0.75 |
| CILS 315 LE | 200 | 1280 | 3.15 | 3.50 | 8.80 | 3.16 | 1240 | 75 | 1490 | 353 | 96.7 | 96.3 | 95.5 | 0.84 | 0.80 | 0.70 |

IMfinity® CILS

Main Electrical & Mechanical Characteristics

IMfinity® 3-phase induction motors
 IP55 Cast iron frame
 Electrical and mechanical characteristics
 IE4 - Powered by the drive

IMfinity® CILS electrical data - on Variable Speed Drive

| Type | 400V / 50Hz | | | | % Nominal Torque Mn at | | | |
|---------------|---------------|---------------|-----------------|----------------------|------------------------|------|------|------|
| | Nominal Power | Nominal speed | Nominal Current | Power factor - Cos φ | 5Hz | 10Hz | 17Hz | 25Hz |
| | Pn - kW | Nn - Min-1 | In - A | 4/4 | | | | |
| 2 pole | | | | | | | | |
| CILS 225 M | 45 | 2978 | 80 | 0.9 | 144 | 144 | 144 | 144 |
| CILS 250 M | 55 | 2976 | 92 | 0.91 | 123 | 158 | 176 | 176 |
| CILS 280 SG | 75 | 2978 | 126 | 0.9 | 158 | 241 | 241 | 241 |
| CILS 280 MG | 90 | 2978 | 151 | 0.89 | 189 | 288 | 288 | 288 |
| CILS 315 SE | 110 | 2978 | 186 | 0.88 | 229 | 352 | 352 | 352 |
| CILS 315 ME | 132 | 2976 | 220 | 0.88 | 275 | 423 | 423 | 423 |
| CILS 315 LE | 160 | 2982 | 273 | 0.88 | 333.5 | 467 | 490 | 514 |
| CILS 315 LE | 200 | 2976 | 329 | 0.91 | 417.3 | 575 | 600 | 642 |
| 4 pole | | | | | | | | |
| CILS 225 S | 37 | 1486 | 71.1 | 0.83 | 238 | 238 | 238 | 238 |
| CILS 225 M | 45 | 1488 | 87.6 | 0.82 | 289 | 289 | 289 | 289 |
| CILS 250 M | 55 | 1488 | 152 | 0.86 | 318 | 353 | 353 | 353 |
| CILS 280 SG | 75 | 1490 | 128 | 0.86 | 315.3 | 450 | 465 | 481 |
| CILS 280 MG | 90 | 1490 | 153 | 0.87 | 377.7 | 577 | 577 | 577 |
| CILS 315 SE | 110 | 1490 | 194 | 0.85 | 706 | 706 | 706 | 706 |
| CILS 315 ME | 132 | 1490 | 230 | 0.85 | 735 | 772 | 797 | 848 |
| CILS 315 LE | 160 | 1488 | 275 | 0.87 | 900 | 900 | 950 | 1028 |
| CILS 315 LE | 200 | 1490 | 355 | 0.84 | 1100 | 1281 | 1281 | 1281 |

IMfinity® CILS Main Mechanical Dimensions

IMfinity® 3-phase induction motors - IE4
IP55 Cast iron frame
Dimensions

IMfinity® CILS Dimensions - B3

Dimensions in millimetres

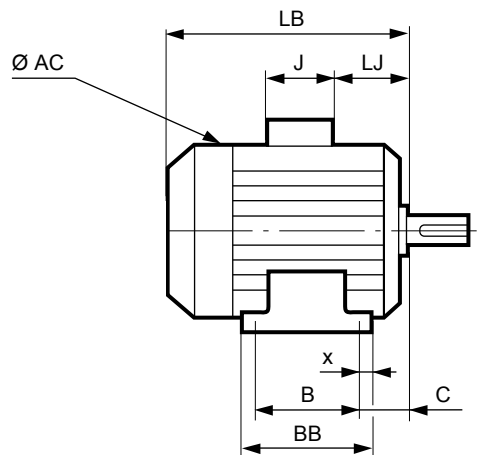
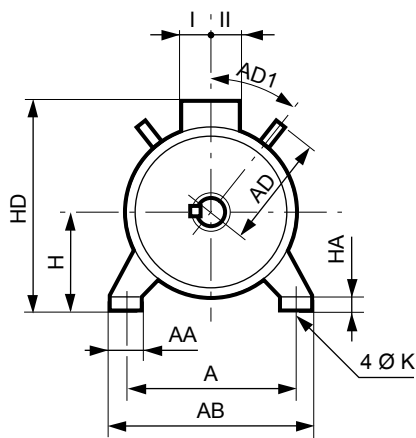

| Type | Main dimensions | | | | | | | | | | | | | | | | | | |
|-------------|-----------------|-----|-----|-----|-----|------|----|------|----|-----|-----|-------|------|------|-----|-----|-----|-----|-----|
| | A | AB | B | BB | C | x | AA | K | HA | H | AC* | HD | LB | LJ | J | I | II | AD | AD1 |
| CILS 225 S | 356 | 426 | 286 | 375 | 149 | 32 | 80 | 18.5 | 27 | 225 | 487 | 652 | 787 | 69.5 | 352 | 175 | 212 | 276 | 45 |
| CILS 225 M | 356 | 426 | 311 | 375 | 149 | 32 | 80 | 18.5 | 27 | 225 | 487 | 652 | 787 | 69.5 | 352 | 175 | 212 | 276 | 45 |
| CILS 250 M | 406 | 476 | 349 | 413 | 168 | 32 | 80 | 24 | 27 | 250 | 487 | 677 | 867 | 69.5 | 352 | 175 | 212 | 276 | 45 |
| CILS 280 SG | 457 | 532 | 368 | 545 | 190 | 51.5 | 86 | 24 | 40 | 280 | 554 | 788.5 | 927 | 44 | 390 | 189 | 179 | 350 | 45 |
| CILS 280 MG | 457 | 532 | 419 | 545 | 190 | 51.5 | 86 | 24 | 40 | 280 | 554 | 788.5 | 927 | 44 | 390 | 189 | 179 | 350 | 45 |
| CILS 315 SE | 508 | 587 | 406 | 662 | 216 | 77.5 | 88 | 28 | 42 | 315 | 554 | 823.5 | 1107 | 44 | 390 | 189 | 179 | 350 | 45 |
| CILS 315 ME | 508 | 587 | 457 | 662 | 216 | 77.5 | 88 | 28 | 42 | 315 | 554 | 823.5 | 1107 | 44 | 390 | 189 | 179 | 350 | 45 |
| CILS 315 LE | 508 | 587 | 508 | 662 | 216 | 77.5 | 88 | 28 | 42 | 315 | 554 | 823.5 | 1107 | 44 | 390 | 189 | 179 | 350 | 45 |

*AC: housing diameter without lifting rings

IMfinity® CILS Main Mechanical Dimensions

IMfinity® 3-phase induction motors - IE4
IP55 Cast iron frame
Dimensions

IMfinity® CILS Dimensions - V1

Dimensions in millimetres

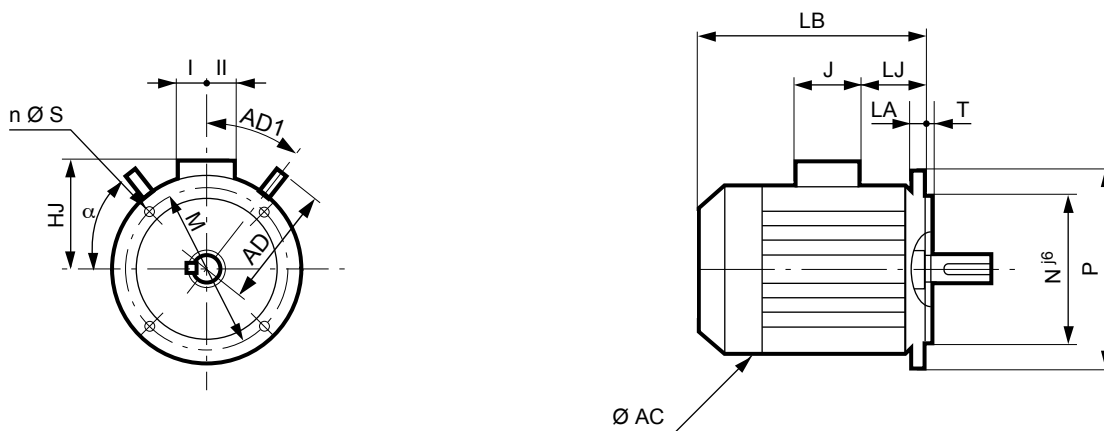

| Type | Main dimensions | | | | | | | | | Symb. |
|-------------|-----------------|-------|-------|------|-----|-----|-----|-----|-----|-------|
| | AC* | LB | HJ | LJ | J | I | II | AD | AD1 | |
| CILS 225 S | 487 | 787 | 427 | 69,5 | 352 | 175 | 212 | 276 | 45 | FF400 |
| CILS 225 M | 487 | 787 | 427 | 69,5 | 352 | 175 | 212 | 276 | 45 | FF400 |
| CILS 250 M | 487 | 867 | 427 | 69,5 | 352 | 175 | 212 | 276 | 45 | FF500 |
| CILS 280 SG | 554 | 927 | 508,5 | 44 | 390 | 189 | 179 | 355 | 45 | FF500 |
| CILS 280 MG | 554 | 927 | 508,5 | 44 | 390 | 189 | 179 | 355 | 45 | FF500 |
| CILS 315 SE | 554 | 1 107 | 508,5 | 44 | 390 | 189 | 179 | 355 | 45 | FF600 |
| CILS 315 ME | 554 | 1 107 | 508,5 | 44 | 390 | 189 | 179 | 355 | 45 | FF600 |
| CILS 315 LE | 554 | 1 107 | 508,5 | 44 | 390 | 189 | 179 | 355 | 45 | FF600 |

*AC: housing diameter without lifting rings

IMfinity® CILS Main Mechanical Dimensions

IMfinity® 3-phase induction motors - IE4
IP55 Cast iron frame
Dimensions

IMfinity® CILS Dimensions - B35

Dimensions in millimetres

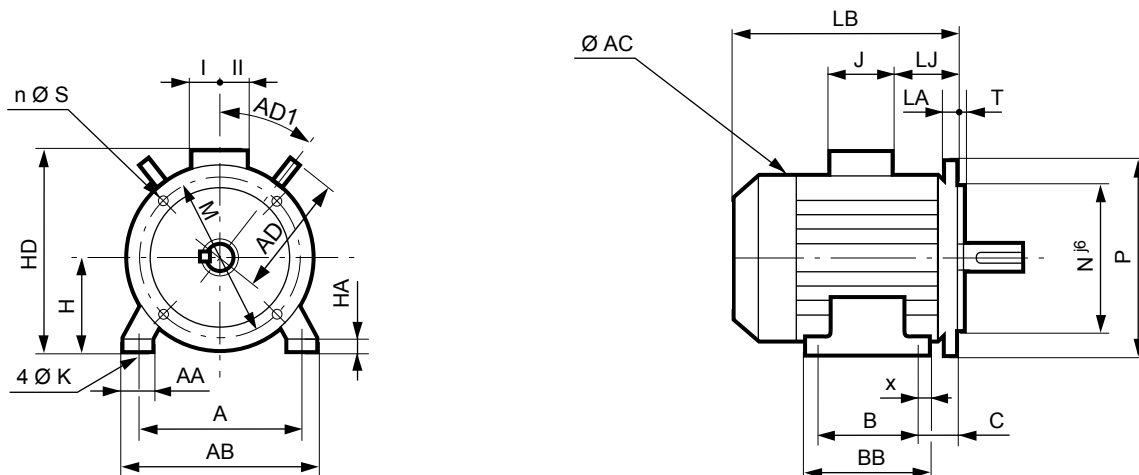

| Type | Main dimensions | | | | | | | | | | | | | | | | | Symb | | |
|------------|-----------------|-----|-----|-----|-----|------|----|------|----|-----|-----|-------|------|------|-----|-----|-----|------|----|-------|
| | A | AB | B | BB | C | x | AA | K | HA | H | AC* | HD | LB | LJ | J | I | II | | AD | AD1 |
| CILS225S | 356 | 426 | 286 | 375 | 149 | 32 | 80 | 18.5 | 27 | 225 | 487 | 652 | 787 | 69.5 | 352 | 175 | 212 | 276 | 45 | FF400 |
| CILS225M | 356 | 426 | 311 | 375 | 149 | 32 | 80 | 18.5 | 27 | 225 | 487 | 652 | 787 | 69.5 | 352 | 175 | 212 | 276 | 45 | FF400 |
| CILS250M | 406 | 476 | 349 | 413 | 168 | 32 | 80 | 24 | 27 | 250 | 487 | 677 | 867 | 69.5 | 352 | 175 | 212 | 276 | 45 | FF500 |
| CILS 280SG | 457 | 532 | 368 | 545 | 190 | 51.5 | 86 | 24 | 40 | 280 | 554 | 788.5 | 927 | 44 | 390 | 189 | 179 | 355 | 45 | FF500 |
| CILS 280MG | 457 | 532 | 419 | 545 | 190 | 51.5 | 86 | 24 | 40 | 280 | 554 | 788.5 | 927 | 44 | 390 | 189 | 179 | 355 | 45 | FF500 |
| CILS 315SE | 508 | 587 | 406 | 662 | 216 | 77.5 | 88 | 28 | 42 | 315 | 554 | 823.5 | 1107 | 44 | 390 | 189 | 179 | 355 | 45 | FF600 |
| CILS 315ME | 508 | 587 | 457 | 662 | 216 | 77.5 | 88 | 28 | 42 | 315 | 554 | 823.5 | 1107 | 44 | 390 | 189 | 179 | 355 | 45 | FF600 |
| CILS 315LE | 508 | 587 | 508 | 662 | 216 | 77.5 | 88 | 28 | 42 | 315 | 554 | 823.5 | 1107 | 44 | 390 | 189 | 179 | 355 | 45 | FF600 |

*AC: housing diameter without lifting rings

IMfinity® CILS Main Mechanical Dimensions

IMfinity® 3-phase induction motors - IE4
IP55 Cast iron frame
Dimensions

IMfinity® CILS Dimensions - Shaft extension

Dimensions in millimetres

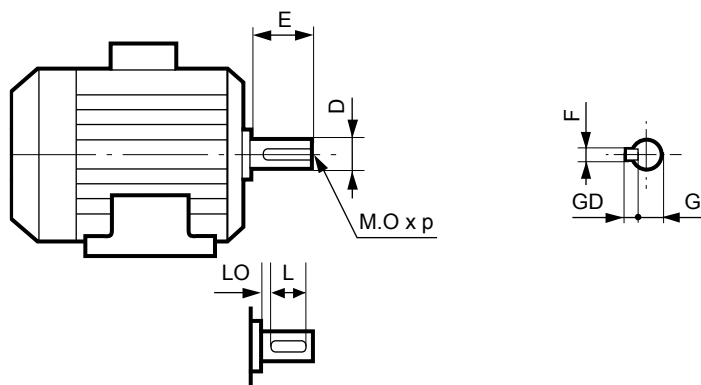

| Type | Main Shaft Dimensions | | | | | | | | | | | | | | | | | |
|------------|-----------------------|----|-------|----|-----|--------|----|-----|----|----|----|-------|------|-----|-----|----|-----|----|
| | 2 pole | | | | | 4 pole | | | | | | | | | | | | |
| | F | GD | D | G | E | O | p | L | LO | F | GD | D | G | E | O | p | L | LO |
| CILS225S | - | - | - | - | - | - | - | - | - | 18 | 11 | 60 m6 | 53 | 140 | M20 | 42 | 125 | 15 |
| CILS225M | 16 | 10 | 55 m6 | 49 | 110 | M20 | 42 | 90 | 20 | 18 | 11 | 60 m6 | 53 | 140 | M20 | 42 | 125 | 15 |
| CILS250M | 18 | 11 | 65 m6 | 58 | 140 | M20 | 42 | 125 | 15 | 18 | 11 | 65 m6 | 58 | 140 | M20 | 42 | 125 | 15 |
| CILS 280SG | 18 | 11 | 65 m6 | 58 | 140 | M20 | 42 | 125 | 15 | 20 | 12 | 75 m6 | 67.5 | 140 | M20 | 42 | 125 | 15 |
| CILS 280MG | 18 | 11 | 65 m6 | 58 | 140 | M20 | 42 | 125 | 15 | 20 | 12 | 75 m6 | 67.5 | 140 | M20 | 42 | 125 | 15 |
| CILS 315SE | 18 | 11 | 65 m6 | 58 | 140 | M20 | 42 | 125 | 15 | 22 | 14 | 80 m6 | 71 | 170 | M20 | 42 | 140 | 30 |
| CILS 315ME | 18 | 11 | 65 m6 | 58 | 140 | M20 | 42 | 125 | 15 | 22 | 14 | 80 m6 | 71 | 170 | M20 | 42 | 140 | 30 |
| CILS 315LE | 18 | 11 | 65 m6 | 58 | 140 | M20 | 42 | 125 | 15 | 25 | 14 | 90 m6 | 81 | 170 | M24 | 50 | 140 | 30 |

IMfinity® CILS Main Mechanical Dimensions

IMfinity® 3-phase induction motors - IE4
IP55 Cast iron frame
Dimensions and options

IMfinity® CILS Dimensions - Flange mounted

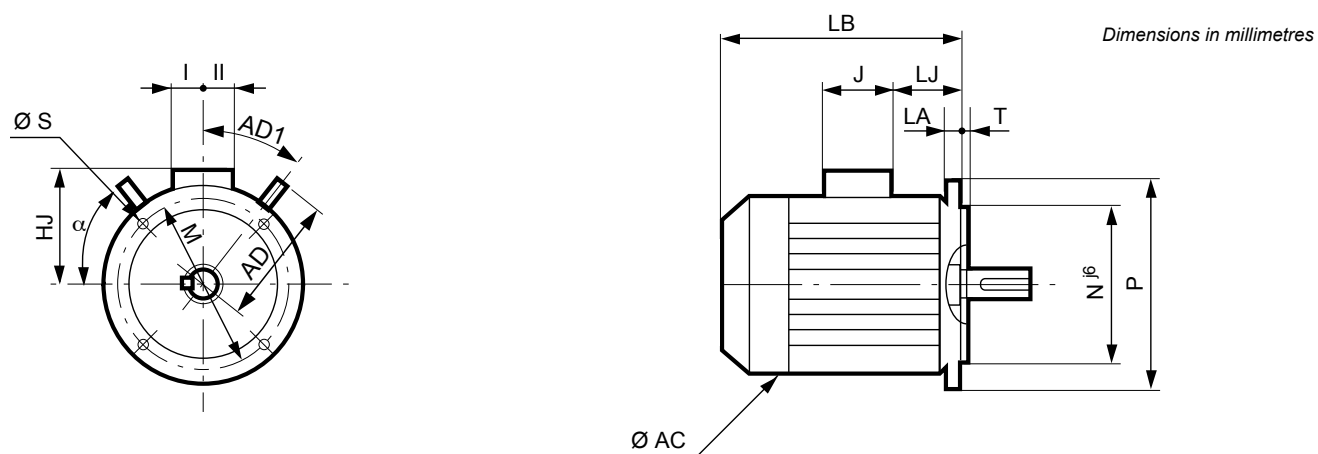

| Type | IEC Symbol | Flange dimensions | | | | | | | |
|--------------|------------|-------------------|-----|-----|---|---|------|------|------|
| | | M | N | P | T | n | α° | S | LA |
| CILS 225 | FF400 | 400 | 350 | 450 | 5 | 8 | 22.5 | 18.5 | 16 |
| CILS 225/250 | FF500 | 500 | 450 | 550 | 5 | 8 | 22.5 | 18.5 | 18 |
| CILS 280/315 | FF500 | 500 | 450 | 550 | 5 | 8 | 22.5 | 18.5 | 24.5 |
| CILS 280/315 | FF600 | 600 | 550 | 660 | 6 | 8 | 22.5 | 24 | 24.5 |

Modified flanges

| Series | Frame size and type | Flange type Mounting form | (FF) Flange mounted | | |
|--------|---------------------|------------------------------|---------------------|--------|--------|
| | | | FF 400 | FF 500 | FF 600 |
| CILS | 225 | all | ● | ◆ | |
| | 250 | all | ◆ | ● | |
| | 280 | all | | ● | ◆ |
| | 315 | all | | ◆ | ● |

● Standard ■ Modified bearing location ◆ Adaptable without modification ○ Please consult Nidec Leroy-Somer

IMfinity® CILS Radial loads

IMfinity® 3-phase induction motors - IE4
IP55 Cast iron frame
Construction
Radial loads

IMfinity® CILS - Standard fitting arrangement

Permissible radial load on main shaft extension with a bearing life L_{10h} of 25,000 hours.

FR: Radial Force

X: Distance with respect to the shaft shoulder

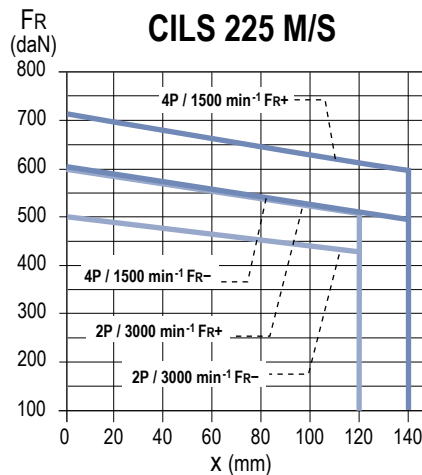
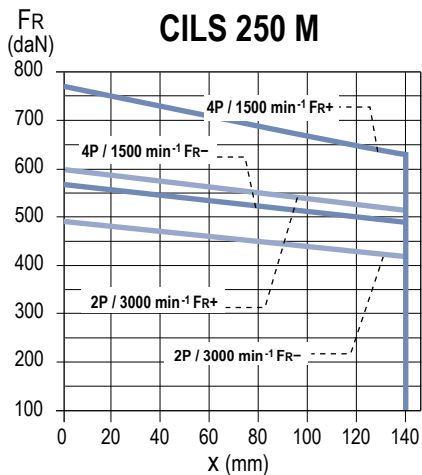
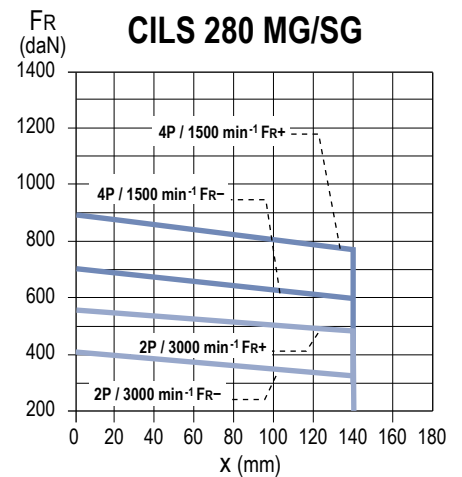
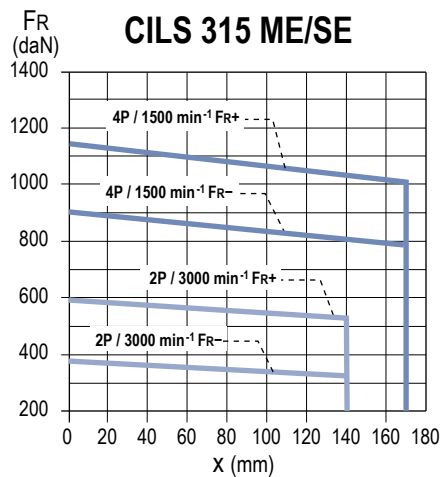
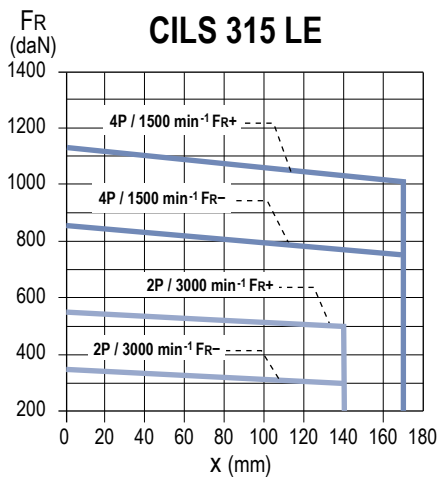

IMfinity® CILS Axial loads

IMfinity® 3-phase induction motors - IE4
IP55 Cast iron frame
Construction
Axial loads

IMfinity® CILS - Horizontal motor

Permissible axial load in daN, For a bearing life L_{10h} of 25,000 hours.

HORIZONTAL MOTOR



| Series | Type | No. of poles | Permissible axial load (in daN) on main shaft extension for standard bearing assembly | | | |
|--------|-------|--------------|---|--------------|----------------------------|--------------|
| | | | IM B3 / B6 - IM B7 / B8 - IM B5 / B35 - IM B14 / B34 | | | |
| | | | 2P: 3000 min ⁻¹ | | 4P: 1500 min ⁻¹ | |
| | | | → | ← | → | ← |
| | | | 25 000 hours | 25 000 hours | 25 000 hours | 25 000 hours |
| CILS | 225 S | 4 | - | - | 354 | 542 |
| | 225 M | 2;4 | 250 | 438 | 348 | 536 |
| | 250 M | 2;4 | 241 | 429 | 324 | 512 |
| | 280 S | 2;4 | 478 | 178 | 660 | 360 |
| | 280 M | 2;4 | 477 | 177 | 655 | 355 |
| | 315 S | 2;4 | 452 | 152 | 772 | 472 |
| | 315 M | 2;4 | 445 | 145 | 767 | 467 |
| | 315 L | 2;4 | 434 | 134 | 744 | 444 |

IMfinity® CILS Axial loads

IMfinity® 3-phase induction motors - IE4
IP55 Cast iron frame
Construction
Axial loads

IMfinity® CILS - Vertical motor

Permissible axial load in daN, For a bearing life L_{10h} of 25,000 hours.

VERTICAL MOTOR / SHAFT FACING UP

| Series | Type | No. of poles | Permissible axial load (in daN) on main shaft extension for standard bearing assembly IM V6 - IM V3 / V36 - IM V19 / V69 | | | |
|--------|-------|--------------|---|--------------|----------------------------|--------------|
| | | | 2P: 3000 min ⁻¹ | | 4P: 1500 min ⁻¹ | |
| | | | 25 000 hours | 25 000 hours | 25 000 hours | 25 000 hours |
| CILS | 225 S | 4 | - | - | 492 | 449 |
| | 225 M | 2;4 | 352 | 376 | 502 | 441 |
| | 250 M | 2;4 | 363 | 357 | 529 | 389 |
| | 280 S | 2;4 | 657 | * | 898 | 218 |
| | 280 M | 2;4 | 662 | * | 914 | 195 |
| | 315 S | 2;4 | 667 | * | 1023 | 329 |
| | 315 M | 2;4 | 682 | * | 1033 | 314 |
| | 315 L | 2;4 | 697 | * | 1049 | 265 |

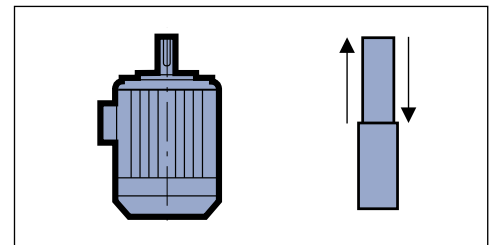

* Please consult Nidec Leroy-Somer

VERTICAL MOTOR / SHAFT FACING DOWN

| Series | Type | No. of poles | Permissible axial load (in daN) on main shaft extension for standard bearing assembly IM V5 - IM V1 / V15 - IM V18 / V58 | | | |
|--------|-------|--------------|---|--------------|----------------------------|--------------|
| | | | 2P: 3000 min ⁻¹ | | 4P: 1500 min ⁻¹ | |
| | | | 25 000 hours | 25 000 hours | 25 000 hours | 25 000 hours |
| CILS | 225 S | 4 | - | - | 680 | 271 |
| | 225 M | 2;4 | 540 | 188 | 690 | 253 |
| | 250 M | 2;4 | 551 | 169 | 717 | 201 |
| | 280 S | 2;4 | 357 | 364 | 598 | 518 |
| | 280 M | 2;4 | 362 | 357 | 614 | 495 |
| | 315 S | 2;4 | 367 | 329 | 723 | 629 |
| | 315 M | 2;4 | 382 | 306 | 733 | 614 |
| | 315 L | 2;4 | 397 | 284 | 749 | 564 |

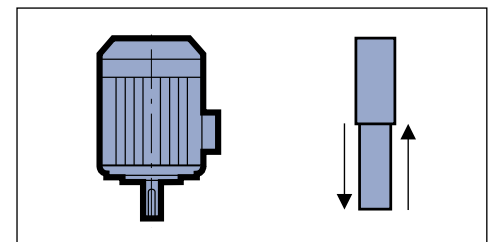

IMfinity[®] CILS Declaration of Conformity

| | | | | |
|---|--|--|--|----------------------------|
|  | PS6 : DOCUMENT MANAGEMENT | | Classement/File: S4T007 | |
| | EU & UK DECLARATION OF CONFORMITY AND INCORPORATION | | Révision: L | Page : 2 / 2 |
| Date: 2023/05/02 | | | Cancels and replaces: S4T007 Révision K from 2022/10/21 | |
| TECHNICAL MANAGEMENT | Doc type : S6T002 Rev D du/from 16/03/2017 | | | <input type="checkbox"/> M |
| | | | <input checked="" type="checkbox"/> I CIMD-E | |

We, **MOTEURS LEROY SOMER**, boulevard Marcellin Leroy CS10015, 16915 ANGOULEME cedex 9, France, and we, **Constructions Electriques de Beaucourt (CEB)** 14, Rue de Dampierre, 90500 BEAUCOURT, France (company of **Nidec Leroy-Somer Holding SA** , boulevard Marcellin Leroy, CS 10015, 16915 ANGOULEME cedex 9, France).

declare, under our own responsibility that the following products:

Moteurs Asynchrones des gammes : LS, FLS, PLS, LSES, FLSES, PLSSES, LSP, LSPR, CILS.

comply with:

- European Directives & United Kingdom Statutory Instrument regulations:
 - Low Voltage Directive : **2014/35/EU & S.I. 2016:1101 ;**
 - ROHS 2 and 3 Directives : **2011/65/EU, 2015/863/EU & S.I. 2016:3032 ;**
 - Eco-design Erp Directive : **2009/125/EC and regulations (UE) 2019/1781 & S.I. 2010 :2617;**

- European standard : **EN 60034-1:2010, EN IEC 60034-7:2022, EN 60034-9:2005/A1:2007, EN IEC 60034-14 :2018 ; EN IEC 63000 :2018 ; EN 62262 :2002/A1 :2021.**

This conformity permits the use of these ranges of products in machines subject to the application of the Machinery Directive 2006/42/EC, provided that they are integrated or incorporated and/or assembled in accordance with, amongst others, the regulations of standard EN 60204(all parts) "Electrical Equipment for Machinery".

The products defined above may not be put into service until the machines in which they are incorporated have been declared as complying with the applicable Directive & Regulations.

Installation of these materials shall be done by a professional who is responsible to comply with the regulations, decrees, laws, orders, directives, application circulars, standards, rules or any other document relating to the installation site. He will be also responsible for the respect of values stamped on motor rating plate(s), instruction manual, installation instructions, maintenance manuals and/or any other document supplied by the manufacturer. MOTEURS LEROY-SOMER and CEB accepts no liability in the event of failure to comply with these rules and regulations.

Signature of technical manager:
A. MARINO



LEROY-SOMER[™]

www.leroy-somer.com

Stay connected:

twitter.com/Leroy_Somer

facebook.com/leroy-somer.nidec

youtube.com/user/LeroySomerOfficiel

linkedin.com/company/leroy-somer



Nidec
All for dreams

© 2025 Moteurs Leroy-Somer SAS. The information contained in this brochure is for guidance only and does not form part of any contract. The accuracy cannot be guaranteed as Moteurs Leroy-Somer SAS have an ongoing process of development and reserve the right to change the specification of their products without notice.

Moteurs Leroy-Somer SAS. Headquarters: Bd Marcellin Leroy, CS 10015, 16915 Angoulême Cedex 9, France. Share Capital: 32 239 235 €, RCS Angoulême 338 567 258.